

# ClanPro®

## STRONG-ARM



### 1 TONNE SCISSOR JACK

MODEL NO: CSJ1000

PART NO: 7624016

## USER INSTRUCTIONS

UK  
CA | CE

ORIGINAL INSTRUCTIONS

GC0 1/26- rev 1

---

## **INTRODUCTION**

---

Thank you for purchasing this CLARKE Scissor Jack.

Before attempting to use this product, please read this manual thoroughly and follow the instructions carefully. In doing so you will ensure the safety of yourself and that of others around you, and you can look forward to your purchase giving you long and satisfactory service.

---

## **GUARANTEE**

---

This product is guaranteed against faulty manufacture for a period of 12 months from the date of purchase. Please keep your receipt which will be required as proof of purchase.

This guarantee is invalid if the product is found to have been abused or tampered with in any way, or not used for the purpose for which it was intended.

Faulty goods should be returned to their place of purchase, no product can be returned to us without prior permission.

This guarantee does not effect your statutory rights.

---

## **LIFTING OPERATIONS AND LIFTING EQUIPMENT REGULATIONS 1998 (LOLER)**

---

This jack, depending on use, may fall within the scope of LOLER. It is the owner's responsibility to determine whether or not it does and, if so, to comply with any applicable requirements in LOLER, for having the jack thoroughly examined.

---

## **SPECIFICATION**

---

Rated Load	1.0 Tonne/1000kg
Min height of saddle	82 mm
Max height of saddle	329 mm
Lifting range under load	200-329 mm

---

## SAFETY PRECAUTIONS

---

1. Ensure that the jack is in good working order. Have any damaged parts repaired or replaced immediately. Use genuine Clarke parts only. The use of unauthorised parts may be dangerous and will invalidate the warranty.
2. Operate the jack in a suitable, well lit work area.
3. Keep the work area clean and tidy and free from unrelated items.
4. Use the jack on level and solid ground, preferably concrete. Avoid soft/unmade ground as the jack may sink in.
5. Ensure the vehicle handbrake is engaged, the engine/motor is switched off and the transmission is in 1st or reverse gear. (or park for automatics)
6. Ensure a minimum distance of 0.5 m between vehicle and static objects such as doors, walls, etc, to allow for the vehicle tilting.
7. Only place the jack under those lifting points recommended by the vehicle manufacturer (see vehicle handbook).
8. Check the lifting point is rigid and centred on the jack saddle.
9. Ensure there are no passengers in the vehicle.
10. Place chocks under the wheels of the vehicle.
11. Ensure all non-essential persons keep a safe distance whilst the jack is in use.
12. Use suitable capacity axle stands under the vehicle before proceeding with any task.
13. Ensure there are no personnel or obstructions under the vehicle before lowering.
14. Use the jack for lifting only, NOT for supporting the vehicle.
15. Take care not to trap fingers in the moving parts of the jack.
16. **DO NOT** operate the jack if damaged.
17. **DO NOT** work under the vehicle until axle stands have been correctly positioned.
18. **DO NOT** allow personnel to operate the jack unless they have read these safety precautions.
19. **DO NOT** use the jack for purposes other than that for which it is designed.
20. **DO NOT** exceed the rated capacity of the jack.
21. **DO NOT** jack up a vehicle if there is a risk of spillage of fuel, battery acid or other dangerous substances.
22. **DO NOT** allow the vehicle to move while supported by the jack.

23. Ensure that you can see the saddle and jacking point throughout the jacking operation in case there is any relative movement.
24. **NEVER** tamper with the product or modify it in any way, as this could prove to be dangerous and will invalidate the guarantee. Only use the product for the purpose for which it is intended.
25. When not in use, store the jack, fully lowered, in a safe, dry, childproof area.



**WARNING: IT IS VERY DANGEROUS TO GO UNDER A VEHICLE WHICH IS SUPPORTED BY A JACK EVEN IF ADDITIONAL SUPPORTS ARE USED. DO NOT GO UNDER A VEHICLE UNLESS IT IS SUPPORTED BY ADEQUATELY RATED AXLE STAND**

---

## OPERATING INSTRUCTIONS

---



**WARNING: BEFORE LIFTING, ENSURE THE SAFETY PRECAUTIONS ARE STRICTLY FOLLOWED.**

1. Prepare the vehicle as mentioned in the safety precautions ensuring the ground on which the jack is to stand is level and solid.
2. Position the jack saddle under the vehicle manufacturers recommended lifting point.
3. No responsibility can be accepted for incorrect use of the jack.

### LIFTING THE VEHICLE

1. Turn the handle clockwise to bring the jack saddle into contact with the recommended lifting point.
2. Ensure the jack is vertical before continuing to turn the handle clockwise and raising the vehicle to the required working height. Turn the handle slowly and evenly to ensure no sudden movements of the vehicle.



## LOWERING THE VEHICLE

1. Slowly turn the handle anti-clockwise to lower the vehicle.



**WARNING: ALWAYS LOWER IN A SLOW AND CONTROLLED MANNER AND ENSURE THERE ARE NO PERSONS OR OBSTACLES BENEATH THE VEHICLE, OR IN THE PATH OF ITS DESCENT.**

---

---

## MAINTENANCE

---

***IMPORTANT: Only fully qualified personnel should attempt maintenance or repair.***

1. Keep the jack clean and lubricate all moving parts with oil on a regular basis.
2. Before each use check for broken, cracked, bent, or loose parts, or any visible damage to welds, saddle, frame and all parts including pins and other fasteners. If any suspect item is found remove jack from service and take necessary action to remedy the problem.

# PARTS LIST & DIAGRAM

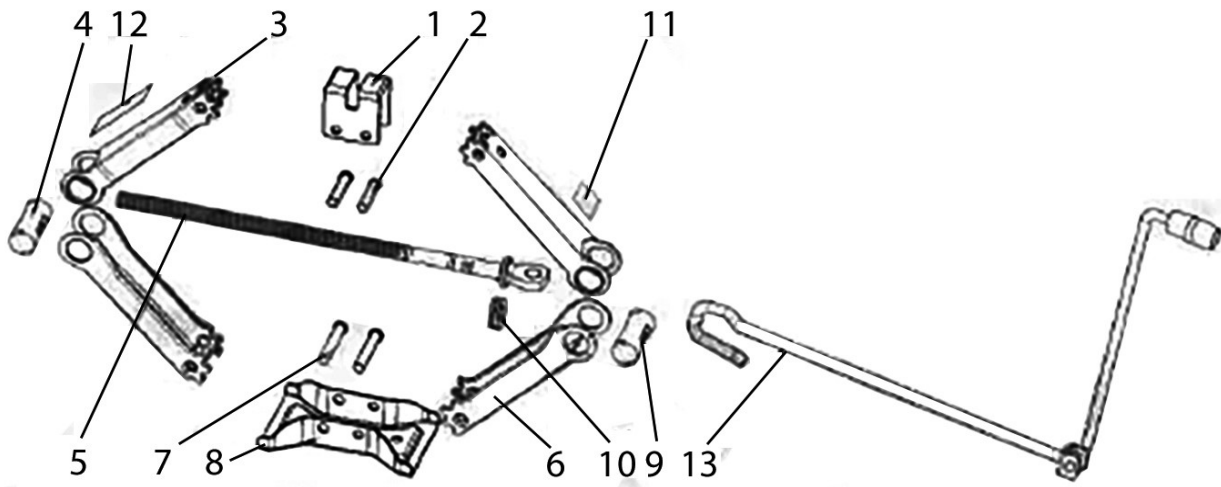

No	Description
1	Saddle
2	Upper pin
3	Upper arm
4	Spacer
5	Threaded rod
6	Lower arm
7	Lower pin

No	Description
8	Base
9	Bracket
10	Bearing
11	Operation direction label
12	Label
13	Handle

# DECLARATION OF CONFORMITY

<b>CE</b>	<b>Clarke<sup>®</sup> INTERNATIONAL</b> Fitzwilliam Hall, Fitzwilliam Place, Dublin 2
<b>DECLARATION OF CONFORMITY</b> This is an important document and should be retained.	
We hereby declare that this product(s) complies with the following legislation: 2006/42/EC <i>Machinery Directive</i>	
The following standards have been applied to the product(s): EN 1494:2000/A1:2008	
The technical documentation required to demonstrate that the product(s) meet(s) the requirement(s) of the aforementioned legislation has been compiled and is available for inspection by the relevant enforcement authorities.	
The CE mark was first applied in: 2024	
Product Description:	Scissor Jack
Model Number(s):	CSJ1000
Serial/Batch Number:	Refer to product/packaging label
Date of issue:	01/11/2024
Signed:	 J.A. Clarke Director
CSJ1000 CE Clarke DOC 110124	
Page 1 of 1	

<b>UK CA</b>	<b>Clarke<sup>®</sup> INTERNATIONAL</b> Hemnell Street, Epping, Essex, CM16 4LG
<b>DECLARATION OF CONFORMITY</b> This is an important document and should be retained.	
We hereby declare that this product(s) complies with the following legislation: <i>The Supply of Machinery (Safety) Regulations 2008</i>	
The following standards have been applied to the product(s): EN 1494:2000/A1:2008	
The technical documentation required to demonstrate that the product(s) meet(s) the requirement(s) of the aforementioned legislation has been compiled and is available for inspection by the relevant enforcement authorities.	
The UKCA mark was first applied in: 2024	
Product Description:	Scissor Jack
Model Number(s):	CSJ1000
Serial/Batch Number:	Refer to product/packaging label
Date of issue:	01/11/2024
Signed:	 J.A. Clarke Director
CSJ1000 UKCA Clarke DOC 110124	
Page 1 of 1	

# A SELECTION FROM THE VAST RANGE OF

# Clarke®

## QUALITY PRODUCTS



### AIR COMPRESSORS

From DIY to industrial, Plus air tools, spray guns and accessories.

### GENERATORS

Prime duty or emergency standby for business, home and leisure.

### POWER WASHERS

Hot and cold, electric and engine driven - we have what you need

### WELDERS

Mig, Arc, Tig and Spot. From DIY to auto/industrial.

### METALWORKING

Drills, grinders and saws for DIY and professional use.

### WOODWORKING

Saws, sanders, lathes, mortisers and dust extraction.

### HYDRAULICS

Cranes, body repair kits, transmission jacks for all types of workshop use.

### WATER PUMPS

Submersible, electric and engine driven for DIY, agriculture and industry.

### POWERTOOLS

Angle grinders, cordless drill sets, saws and sanders.

### STARTERS/CHARGERS

All sizes for car and commercial use.

## PARTS & SERVICE: 0208 988 7400

**Parts Enquiries**  
[Parts@clarkeinternational.com](mailto:Parts@clarkeinternational.com)

**Servicing & Technical Enquiries**  
[Service@clarkeinternational.com](mailto:Service@clarkeinternational.com)

SALES: UK 01992 565333 or Export 00 44 (0)1992 565335

**Clarke** INTERNATIONAL Hemnall Street, Epping, Essex CM16 4LG  
[www.clarkeinternational.com](http://www.clarkeinternational.com)